

Description

The AIM FA series single-phase Active Harmonic Filters (AHFs) are designed to isolate harmonic currents and thereby protect equipment on your power distribution system, with or without compensation displacement power factor (dpf – phase shift).

The AIM FA AHFs should be used in power circuits of widely dispersed computer networks in banks, dealing rooms and ‘smart devices’ in buildings.

The AIM FA series single-phase AHFs can be installed without modification to existing power line wiring, and will operate without any adjustments as equipment variations cause power line conditions to change.

Benefits

- Reduction of harmonic distortion;
- Reduction of peak line current;
- Reduction of rms current;
- Reduction of start-up current on switch on;
- Reduction of potentially harmful network interference;
- Reduction of power cable cross-section;
- Reduction in size of line fuses;
- Prevents overheating in power distribution equipment and wiring, often referred to as ‘smoking neutrals’;
- Prevents unnecessary limitations on normally available power;
- Prevents interference, ‘glitches’ and loss of data in computers, telephone and other information transmission equipment;
- Prevents damage to power sensitive user equipment.



19 inch Rack Version

Operating Principles

The following are shown on the diagram: input fuses, surge protection system, passive LC Filter, transistor inverter (IGBT), capacitor bank C_f , connected in a steady-voltage circuit, and control unit. The control unit determines the shape of the current generated by the inverter by comparing the load current with a model sine wave. This current results in a sinusoidal flow of current from the AC network when added to the current of the load. The operation of the active filter is possible due to a bi-directional energy flow within the inverter-capacitor system (C_f).

Fig 1. Current Flow Diagram

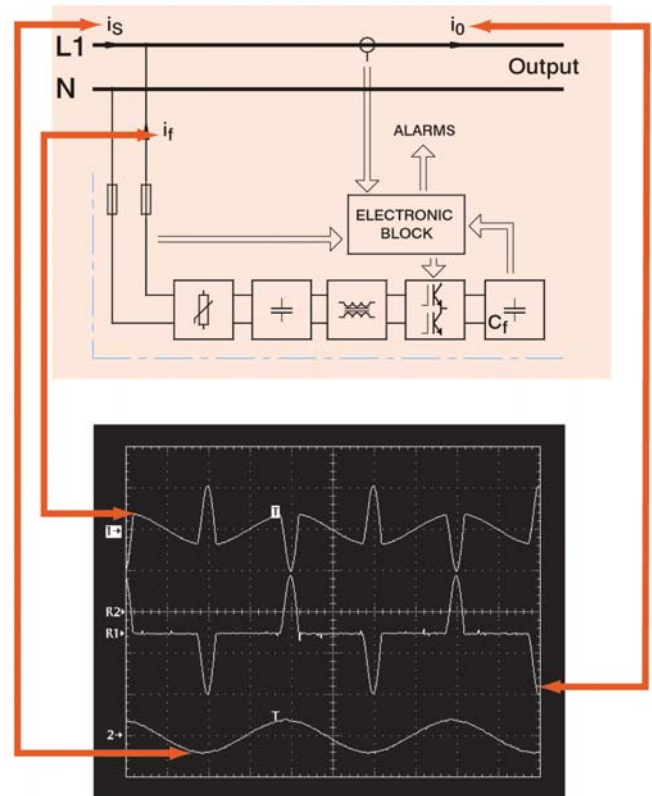

15Amp AIM AHF

Efficiency of the Active Filters - Nonograms

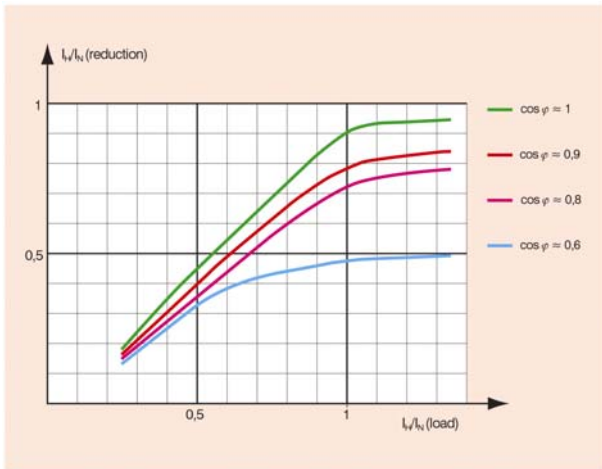

Total load current harmonic reduction
– compensation displacement power factor ON

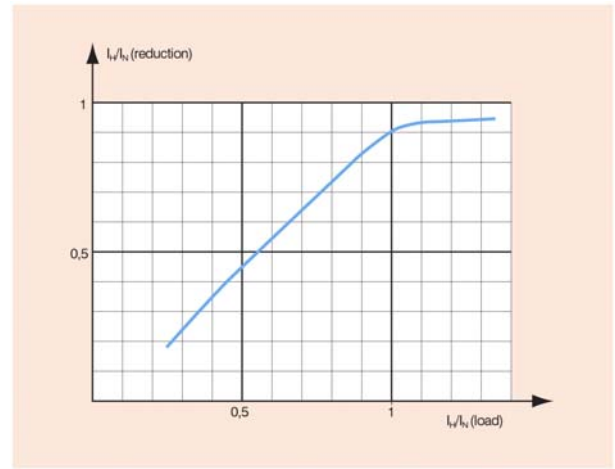

Total load current harmonic reduction
– compensation displacement power factor OFF

ATTENUATION COEFFICIENT OF HARMONICS (for nominal load)

Component number	2	3	4	5	7	8-11	12-15	16-21	22-27	28-31
Load I_H / Line I_H	10	15	20	25	30	30	15	7	7	6

System Configurations

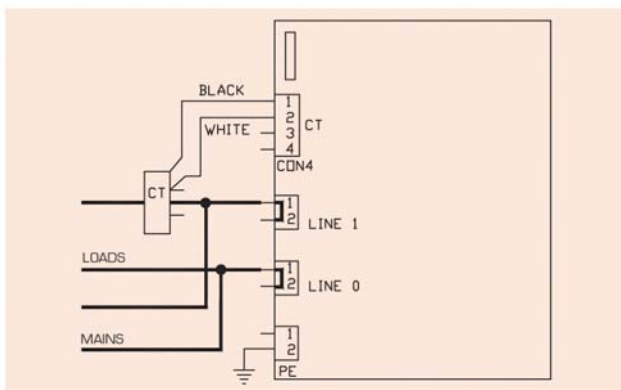

Terminals of phase circuits
for the single phase filter

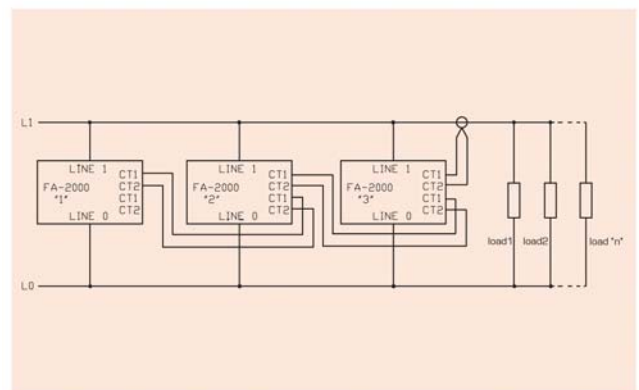

Installation diagram for the parallel operation
of three single-phase filters

Typical Measurements for PC-Type Load

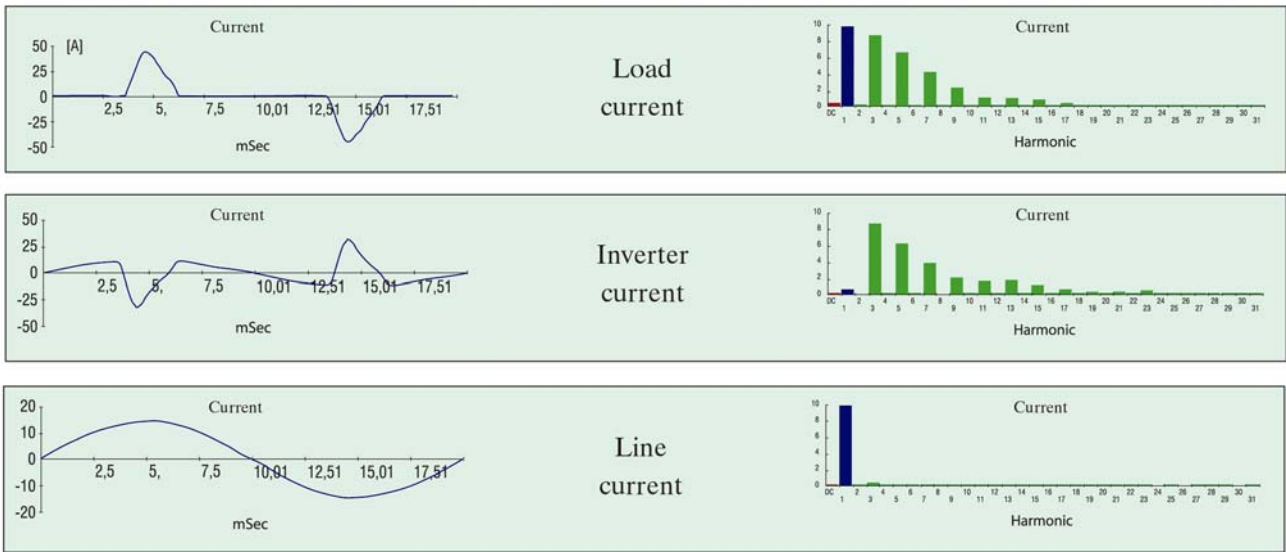

Load current: Single Phase Readings					Line current: Single Phase Readings				
	Frequency	Power	RMS	Current		Frequency	Power	RMS	Current
	49,97	2,21	15,46	228,2		49,97	2,25	15,46	228,3
		3,53	45,99	316,3			2,26	45,99	316,1
		0,16	0,3	0,3			0,0	0,3	0,3
		14,59	2,98	1,39			4,75	2,98	1,52
	4° lead	0,63	2,08	2,08		4° lead	0,64	2,17	2,17
		1,00	16,03	4,8			1,00	1,22	4,9
Harm.	Freq.	V Mag	%V RMS	V F°	I Mag	%I RMS	I F°	Power (KW)	
DC	0,00	0,34	0,15	0	0,43	2,75	0	0,00	0,00
1	49,97	228,14	99,98	0	9,79	63,39	4	2,23	2,25
2	99,94	0,25	0,11	103	0,34	2,18	91	0,00	0,00
3	149,90	1,77	0,77	132	8,59	55,62	-172	0,01	0,00
4	199,87	0,03	0,01	-134	0,22	1,42	-93	0,00	0,00
5	249,84	3,97	1,74	170	6,53	42,23	15	-0,03	0,00
6	299,81	0,09	0,04	68	0,08	0,53	82	0,00	0,00
7	349,78	1,81	0,79	-18	4,18	27,06	-155	-0,01	0,00
8	399,74	0,05	0,02	77	0,03	0,20	128	0,00	0,00
9	449,71	0,38	0,16	-106	2,19	14,20	47	0,00	0,00
10	499,68	0,03	0,01	-59	0,09	0,57	-76	0,00	0,00
11	549,65	0,09	0,04	65	1,18	7,61	-88	0,00	0,00
12	599,62	0,08	0,03	90	0,08	0,53	94	0,00	0,00
13	649,58	0,28	0,12	-33	1,04	6,76	139	0,00	0,00
14	699,55	0,02	0,01	-59	0,03	0,20	-93	0,00	0,00
15	749,52	0,09	0,04	-32	0,88	5,70	-20	0,00	0,00
16	799,49	0,03	0,01	-120	0,02	0,12	-61	0,00	0,00
17	849,46	0,16	0,07	53	0,49	3,16	174	0,00	0,00
18	899,42	0,06	0,03	122	0,04	0,28	94	0,00	0,00
19	949,39	0,20	0,09	-60	0,09	0,57	40	0,00	0,00
20	999,36	0,05	0,02	-96	0,04	0,24	-107	0,00	0,00
21	1049,33	0,02	0,01	-78	0,22	1,42	-23	0,00	0,00
22	1099,30	0,05	0,02	57	0,01	0,08	34	0,00	0,00
23	1149,26	0,08	0,03	133	0,25	1,62	163	0,00	0,00
24	1199,23	0,02	0,01	111	0,03	0,20	148	0,00	0,00
25	1249,20	0,08	0,03	-66	0,12	0,77	-32	0,00	0,00
26	1299,17	0,02	0,01	115	0,03	0,20	-32	0,00	0,00
27	1349,13	0,08	0,03	25	0,11	0,73	39	0,00	0,00
28	1399,10	0,00	0,00	-164	0,03	0,16	119	0,00	0,00
29	1449,07	0,08	0,03	156	0,21	1,38	-160	0,00	0,00
30	1499,04	0,05	0,02	-60	0,01	0,08	172	0,00	0,00
31	1549,01	0,05	0,02	-4	0,21	1,33	17	0,00	0,00

Product Specifications

Technical Data: AIM FA Series Single Phase Active Harmonic Filters

Model Number	Input Voltage (V)	Frequency (Hz)	Output Current (Arms)	Corrected Power (KVAR)	Power Losses (W)	Dimensions H x W x D (mm)	Weight (Kg)
FA-2000-120	120	60	30	3	170 W	210 x 175 x 370	9
FA-2000-208	208	60	15	3	150 W	210 x 175 x 370	9
FA-2000-230	220/230	50	15	3	150 W	210 x 175 x 370	9
FA-2000-380	380/400	50	10	3	120 W	210 x 175 x 370	9

General Specification

Input Voltage

Input Frequency:

Ambient Temperature:

Altitude:

Humidity:

Input Interrupting Capability:

Transient Withstanding Capacity:

Parameter Adjustments:

Protection Class

Control and Indication Panel

Remote Indicator (Relay Output)

Output Performance: (Typical)

- Single Phase – 120, 208, 220, 230, 380, 400V; $\pm 10\%$
- 50 or 60 Hz, $\pm 1\%$
- Enclosed Operating – From 0°C to 40°C
- Chassis Operating - From 0°C to 55°C
- Storage - From -30°C to +85°C
- Sea level to 1000 Meters without derating
- 95% noncondensing
- Less than 15KVA – 100,000 A fuses.
- Greater than 15KVA – 200,000 A fuses.
- Per IEEE 587.
- None required.
- IP 20
- Switch
 - On / Off / Reset
- Indicators
 - Power Applied
 - Operate
 - Fault
 - At maximum capacity
 - Temp Warning
- Temperature
- Voltage
- Fault
- % THD – Less than 5% total, no one harmonic in excess of 3% (voltage).
- % TCD - Less than 5% total, no one harmonic in excess of 3% (current).

Contacts

AIM Europe
Balvaddi House
12 Ferry Row
Fairlie, Ayrshire
KA29 0AJ
Scotland
United Kingdom
Tel: +44 (0) 1475 568 423
Fax: +44 (0) 1475 568 808
email: powerquality@aimeurope.com
www.aimeurope.com

APT AIM Energy, Inc
(Corporate Office)
Port Ludlow
WA 98365, USA
Tel: +1 360 437 7779

AIM Canada
Ontario, L4B 1C7
Canada
Tel: +1 905 709 8970

Westek Electronics PTE Ltd
Victoria 3026, Australia
Tel: +61 3 9369 8802

AIM Spain
Kerideke SL
Madrid, Spain
Tel: +34 629 447 200

Master Distributor - Latin America
U.S. Mex Manufacturing Corp.
California 91950, USA
+1 619 474 3331